

# MEASUREMENT WORKSHEET

Completing this form is necessary to move forward with hardware selection. Measure your existing hardware and complete this form to easily guide your way through your gear choice options at [www.gowindowgo.com](http://www.gowindowgo.com).

## MANUAL TONGUE WITH SHOOTBOLT VERSION

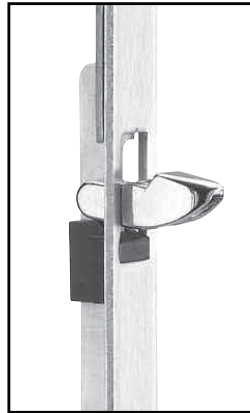

Top tongue position of	=	Middle extension length of
9.84"	=	13.43"
23.62"	=	27.20"
29.25"	=	32.83"
41.34"	=	44.92"
46.97"	=	50.55"
59.06"	=	62.64"
76.77"	=	80.35"

② Faceplate Width

## Fill in blank or Circle Measurements

**IMPORTANT!** Your number must match one of the sizes listed.

- ① Handle Height: \_\_\_\_\_ Gear is for 36" height only
- ② Faceplate Width: \_\_\_\_\_ 5/8" (16mm) or 3/4" (20mm)
- ③ Backset: \_\_\_\_\_ 1-3/8" / 1-3/4" / 2-3/8" / 2-3/4"
- ④ Deadbolt Throw: \_\_\_\_\_ 1/2" or 1" in thrown position
- ⑤ Overall Length: \_\_\_\_\_ Top to bottom of faceplate
- ⑥ Bottom Tongue Position: \_\_\_\_\_ 24.41" only
- ⑦ Top Tongue Position: \_\_\_\_\_ 9.84" / 23.62" / 29.25" / 41.34" / 46.97" / 59.06" / 76.77"
- ⑧ Middle Extension Length: \_\_\_\_\_ Determine by matching your top tongue position on above chart
- ⑨ Top Extension Length (range): \_\_\_\_\_ Must take overall hardware length (5) and subtract 37.61". Subtract this number from the middle extension length (8). Answer is your top extension length (range).

See definition of terms on following page.

**Diamond Parts**  
715-218-5715



**DIAMOND**  
WHOLESALE LLC

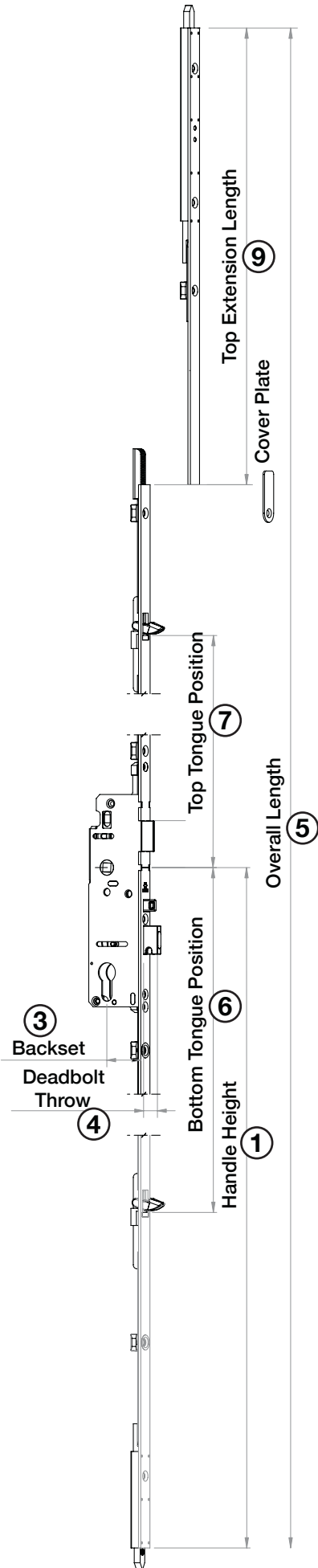

# GLOSSARY OF TERMS

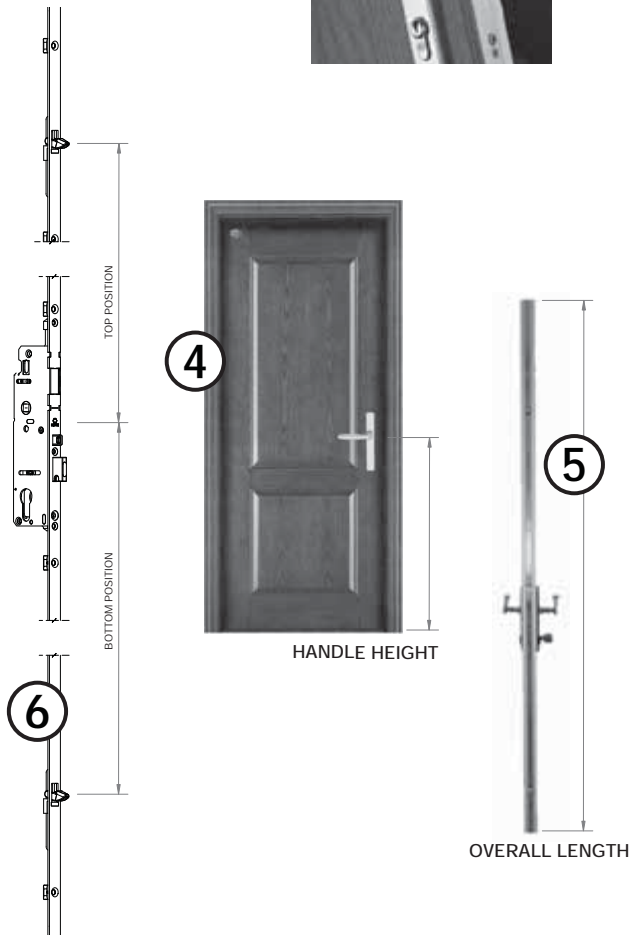
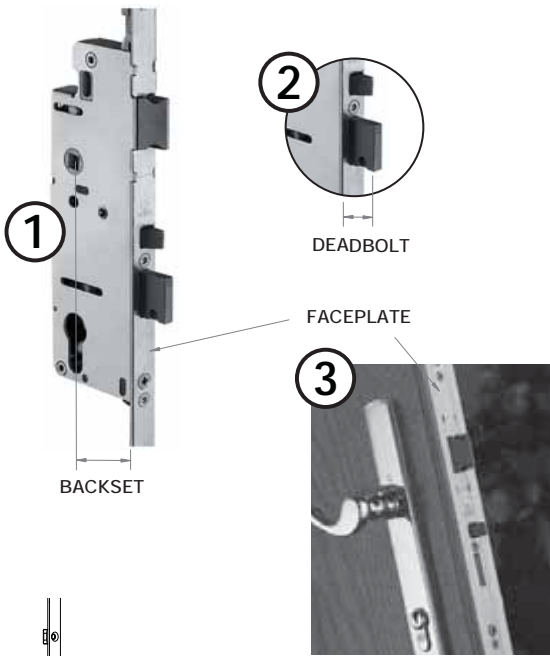

- ① **Backset:**  
Distance from edge of door to center of handle
- ② **Deadbolt Throw:**  
How far out the deadbolt protrudes on a lock; distance from edge of faceplate to end of deadbolt
- ③ **Faceplate:**  
The visible part of the lock that runs up and down the edge of the door; typically sits flush with the edge of door
- ④ **Handle Height:**  
Distance from bottom of door to center of handle
- ⑤ **Overall Length:**  
How long the lock is from top to bottom  
*\*Note this can be different than the height of the door*
- ⑥ **Locking Position:**  
Distance from center of door handle to each of the locking points on the lock
- ⑦ **Locking Device:**  
Any type of mechanism that locks the door by engaging with a strike; in a multipoint lock, these are connected to the main gear and are thus operated and controlled with the central handle; some examples of common locking devices are included below:

**Roundbolts:** Roundbolts extend out from the lock into cavity on passive door when engaged.

**Shootbolts:** Shootbolts operate at the top and/or bottom of a door and extend into the floor or top of the door jamb, thus keeping the door in place.

**Rollers:** Rollers slide up and down on the faceplate of a multipoint lock; when engaged, they slide down into a curved strike, and the door cannot open until they are disengaged and lifted up and out of the strike.

**Tongues:** Tongues extend out from the lock and into a cavity in the door jamb or passive door when engaged.

